

MRL Team Description 2014

Amin Ganjali Poudeh, Saeid Esmaeelpourfard, Adel HosseiniKia,
Hamidreza Jamaati Tafti and Aras Adhami-Mirhosseini,

Islamic Azad University of Qazvin, Electrical Engineering and Computer Science Department,
Mechatronics Research Lab, Qazvin, Iran
a.adhami@ece.ut.ac.ir

Abstract. MRL Small Size Soccer team, with more than five years of experience, is planning to participate in 2014 world games. In this paper, we present an overview of MRL small size team. Having attained the third place in 2010, 2011 and 2013 competitions, last year we enhanced the reliability and achieved higher accuracy. Now, finalizing our debugging tools like 3D simulator, comprehensive user interface and decision systems restructuring, aided us to evaluate the entire system software from low - level control to high level strategies. Finally, by overcoming electronic and mechanical structure problems, promoted the robots ability in performing more complicated tasks.

1 Introduction

MRL team started working on small size robot from 2008. In 2013 Robocup, the team was qualified to be in semi-final round and achieved the third place. In 2014 the team goals are: 1) preparation for double-sized field games and 2) more dynamic and intelligent behavior. This year, the main structure of the robot is the same as 2013 robots, see [1] for details.

Some requirements to reach this target are achieved by redesigning the electrical and mechanical mechanisms. Moreover, simple learning approaches and advanced control methods are employed in the way of more dynamic play. Evaluation by software tools, like online debugger and simulator which is detailed more in [2], makes the design procedure and verification faster.

This paper is organized as follows: First of all, the software architecture which includes our approaches in high level strategies, navigation subsystem and verification tools is described in section 2. The Electrical design including ARM micro controller together with FPGA, and other accessories of robots onboard brain, is explained in section 3. Description new mechanical structure, which modifies the capabilities of the robots with smooth and reliable motion, is the subject of section 4.

1 Software

In this section, the main parts of software are presented. It is shown how our system debugger helps us to design a robust controller and microprocessor programs. MRL software team had been started a high level analyzer project that will be shown in the next section. Our simulator's features will be presented afterward. Our game plan contains many parts like play, roles and skills, Fig. 1. In this paper concentration on a layer, named strategy (sub play), is explained in the following.

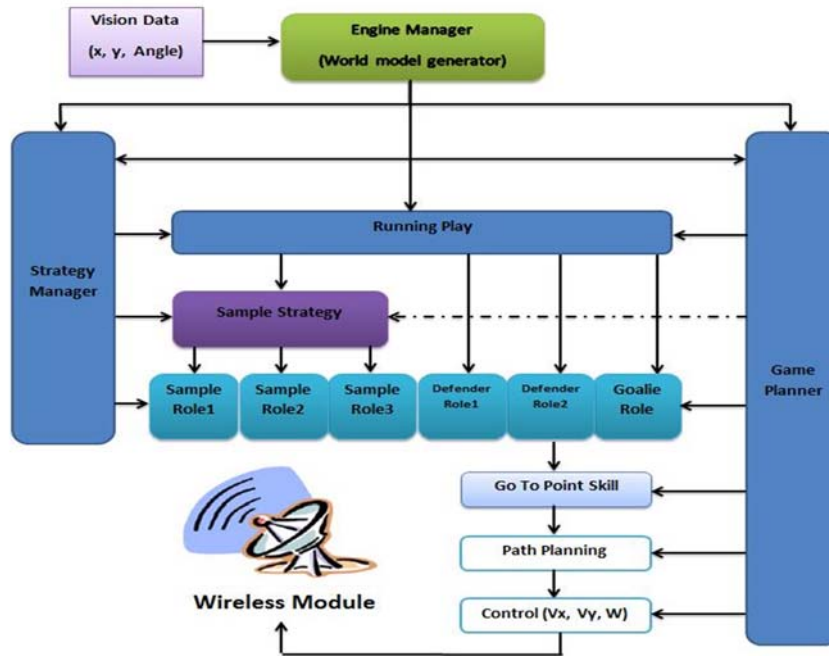

Fig. 1. Block diagram of AI structure

2.1. Strategy

Strategies are a layer that had been added to our software architecture. Strategies have been placed between Roles layer and plays layer. Roles like “Defender” or “Attacker” are simple roles which are used in strategies. Each play can be includes several strategies (sub plays) and several roles can engage in a strategy. Each strategy has several states that conditions of transition are determines the transition time between states. For example free kick play has two types of strategies. The first strategy is defending and second is attacking, Fig. 2.



Fig. 2. Two types of strategies

2.2. Navigation System

By now, we employed indirect trajectory tracking method which contains path planning and trajectory generation. Rapidly Random Tree (RRT) is used as a path planner in our navigation subsystem. A simple RRT path planner tries to generate a tree from an initial state to a goal state using random points in a way that the tree does not encounter obstacles. In the procedure of expanding the tree all the random points that may be in the region of obstacles will be eliminated. Moreover, if there is a reachable path from each random point to goal, the desired tree will be completed. After reaching the goal, usually the generated tree is too rugged for tracking. Before starting to move on path, the generated path must be made smoother. For this purpose we benefit from a heuristic algorithm. In Fig. 3 the RRT path and smoothed one is depicted. This year, we start to test other approaches for motion planning. The results show that better performance may be obtained by direct trajectory tracking methods. The main drawbacks of these methods are the computational cost. Now, the team is working on the optimization of calculations.

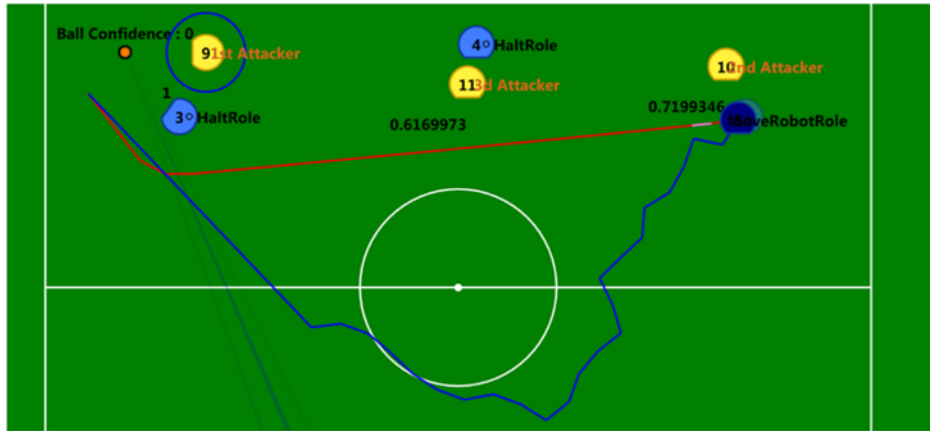

Fig. 3. The generated path before and after smoothing

For moving on the generated path, we need to calculate a speed vector for each point on the path. For this we should consider the distance from beginning to each point and curvature from that point to the end of path. We force the robot to reach all the points sequentially with the calculated velocity in each step.

2.3. Online internal debugging

As stated before, to debug onboard control modules such as wheels speed and controller parameters a comprehensive debugging tool is required. Simultaneous investigation of the commanded velocities and the robot velocities computed via vision and encoder data is acquired. This approach facilitated analysis and design of the PID controller, wireless module data or any of our internal components. We have designed an online link between our microprocessor and AI systems in order to enable us to debug and maintain all controllers and filters easily and in a time optimal fashion. Fig. 4. Shows our internal debugger graphical interface. In this figure the mentioned data are shown. If the desired velocity and robot speed measured by vision are similar, the control performance will be suitable.



Fig. 4. User Interface of the AI, showing the viewer and settings Box

2.4. High level Analyzer

One of the most significant modifications we have made to our MRL2013 team, is the optimization of a decision making layer as a high-level analyzer. Log files from SSL Vision of all MRL games should be recorded during a game. The final stage will be extracting the opponent team strategies and finding the best tactic to cope with it. Although, it is too far from implementation, the preliminary steps are under construction. Strategy model consists of different parameters such as the number of robots in each position e.g. defender robots, attackers and free robots. Our goal is distinguishing the best feasible strategy from these models dynamically. For instance, if the opponent team is attacking with one “attacker”, one marker robot should be placed to block it. If there are two attackers in non-dangerous area (far from penalty area), there should be still one blocker robot. Of course, such high level decision makings can be implemented properly when each task in lower levels could be performed in a perfect manner. Before obtaining such performances a simulator will help the high level designer to evaluate ideas.

The core system of MRL2014 simulator is the same as MRL2013. One of the significant changes in the simulator is considering noise signals in wireless system. We found that this noise has a close relation with distance. Sometimes data packets are not properly received by robots. A probabilistic model for data transfer has been introduced to simulate a real wireless system. Measuring lost data compared with the size of sent packets shows a detectable relation with distance between the robot and the wireless transmitter (d). A Gaussian distribution is fitted to the wireless noise with the mean (m) and variance (σ) related to the distance ((1) and (2)). More details about these contributions are explained in [2].

$$m = (1 + \frac{2}{\pi} \arctan(0.4(d - 5))) \quad (1)$$

$$\sigma = 0.03 \log(1 + \frac{d}{5}) \quad (2)$$

3 Electrical Design

The robot electronic consist of an Altera™ Cyclone® FPGA linked to an ARM core same as last years. The major change during the last year in this section is implementation of parallel motor controllers in FPGA, since calculation of PID controllers in software requires a lot of CPU time. Moreover, moving controllers to FPGA, the ARM processor can dedicate other task with less interrupts.

Main board of the robot, which mainly derives wheels and dribbler motors, is illustrated in Fig. 5. The board is the same as MRL2013, [3].

For optimizing robot's chip kicker we have decided to simulate desired solenoid with Femm by using the results of previous kicker coil core data. As a result it reduces 100gr of robot weight mainly from solenoid and capacitor weight totally.



Fig. 5. The electronic main board

3.1 Accessories:

1. **Wireless Module:** The main board receives commands from the AI computer by wireless module. Our communication system is based on the nRF2401 wireless module which is a programmable radio transceiver with a working frequency between 2.4 and 2.52 GHz and a baud rate of 2 Mbit/s . So it decreases the delay of communication to around a few milliseconds.
2. **Battery:** Each robot uses 4/5-cells of lithium polymer (LIPO) battery, with capacity of 1750 mAH, can preparation 61A continuously.
3. **Kicker Board:** The kicker board is designed to provide power for two kicking systems. It contains one MOSFET for charging and two for kicking. We added a current sensor to set a threshold for current. Since power deception in switching MOSFET increase the temperature and cause damages, we utilize a temperature sensor to avoid critical situation.
4. **IR sensor:** For recognizing the ball position in dribbler we used two IR sender and receiver sensors. To protect sensors and better ball positioning, the location and structure of sensors reshaped.

Due to surrounding lights and importance of ball detection, the IR sensors are used in specific frequency. To this end, the transmitter sensor is driven by a square wave with specific frequency and receiver sensor output voltage is filtered by a narrow band-pass filter.

4 Mechanical Design and construction

Typically, the main portions of mechanical structure of a small size robot, includes 4 wheels, two kickers, a dribbler and the motion transformer system, Fig. 6. Due to some drawbacks in the previous proposed design, we decided to improve both, the mechanical design and the construction materials.

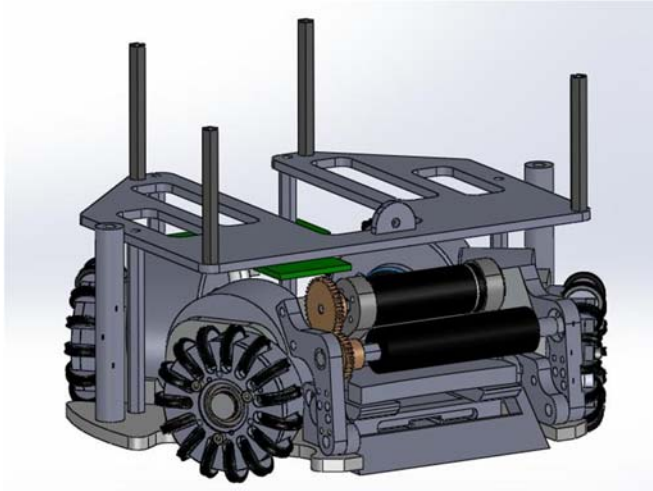

Fig. 6. Robot 2014 mechanical structure

The issues we focus on are finding the optimized orientation and arm length of chip kick, the location of spin back and IR sensors, and also some modification on our dribbling system.

In order to develop a chip kick with precised range, we construct a simulator in SolidWorks motion analysis environment, where the robot dribbling system is modeled (Fig. 7). Using this simulator, lots of tests are performed on the designed chip kick and the lightest mechanism with best performance is selected.

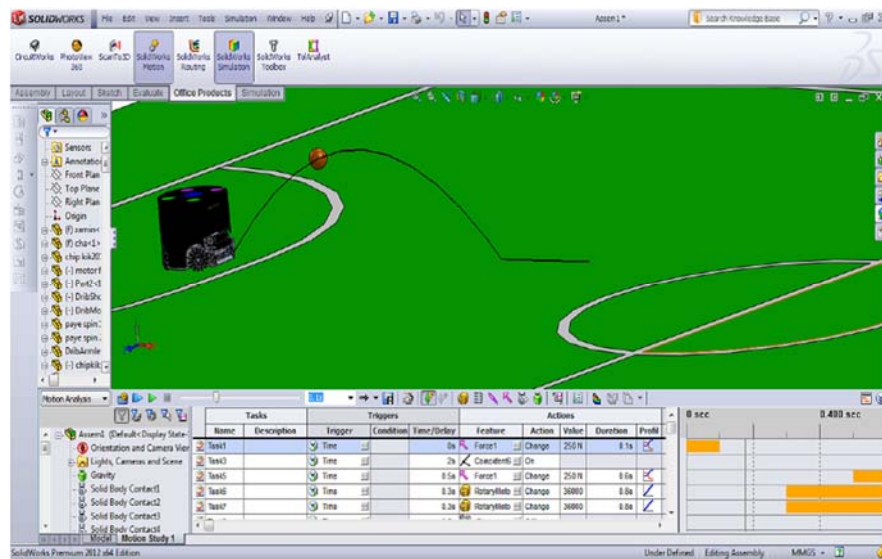

Fig. 7. SolidWorks Motion Analysis environment

In the previous version of MRL robots, the wheels radius of the robot was selected to be 29(mm), however, due to lack of enough acceleration, in the present version wheels radius is reduced by 4(mm). Besides, 15 rollers are employed in each wheel, Fig. 8.

The robot uses dribbling system to improve the capacity of ball handling, the dribbler is a shaft covered with silicon tube that connected to high speed brushless motor, Maxon EC16 Brushless, with 1:1 gear ratio.

The MRL 2014 Robot has ability to kick the ball up to speed of 9 m/s and also can run at a speed 3 m/s and 4 m/s^2 . The Robot has also the custom-made flat solenoid for chip kick system which is attached to chassis, under the main solenoid. The chip kick has a 45 degree hinged wedge which is capable of kicking the ball up to 4m before it hits the ground. This year, we are going to replace it with an optimized cylindrical solenoid.



Fig. 8. Wheels of MRL 2013

References

1. Adhami-Mirhosseini, A., Jamaati Tafti, H., Asadi Dastgerdi, S., Ganjali, A., Esmaeelpourfard, S., and Beik Mohammadi, H., MRL 2013 Team Description, In Proceedings of the 17th International RoboCup Symposium, Eindhoven, Netherland, (2013).
2. Bakhshandeh, O., M., Sharbafi, "Modeling and Simulating of Omni Directional Soccer Robots" 2011 IEEE 3rd International Conference on Computer Modeling and Simulation (ICCMS 2011), Mumbai, India, (2011).
3. Ganjali Poudeh, A., Asadi Dastgerdi, S., Esmaeelpourfard, S., Beik Mohammadi, H., and Adhami-Mirhosseini, A., MRL 2013 Extended Team Description, In Proceedings of the 17th International RoboCup Symposium, Eindhoven, Netherland, (2013).