

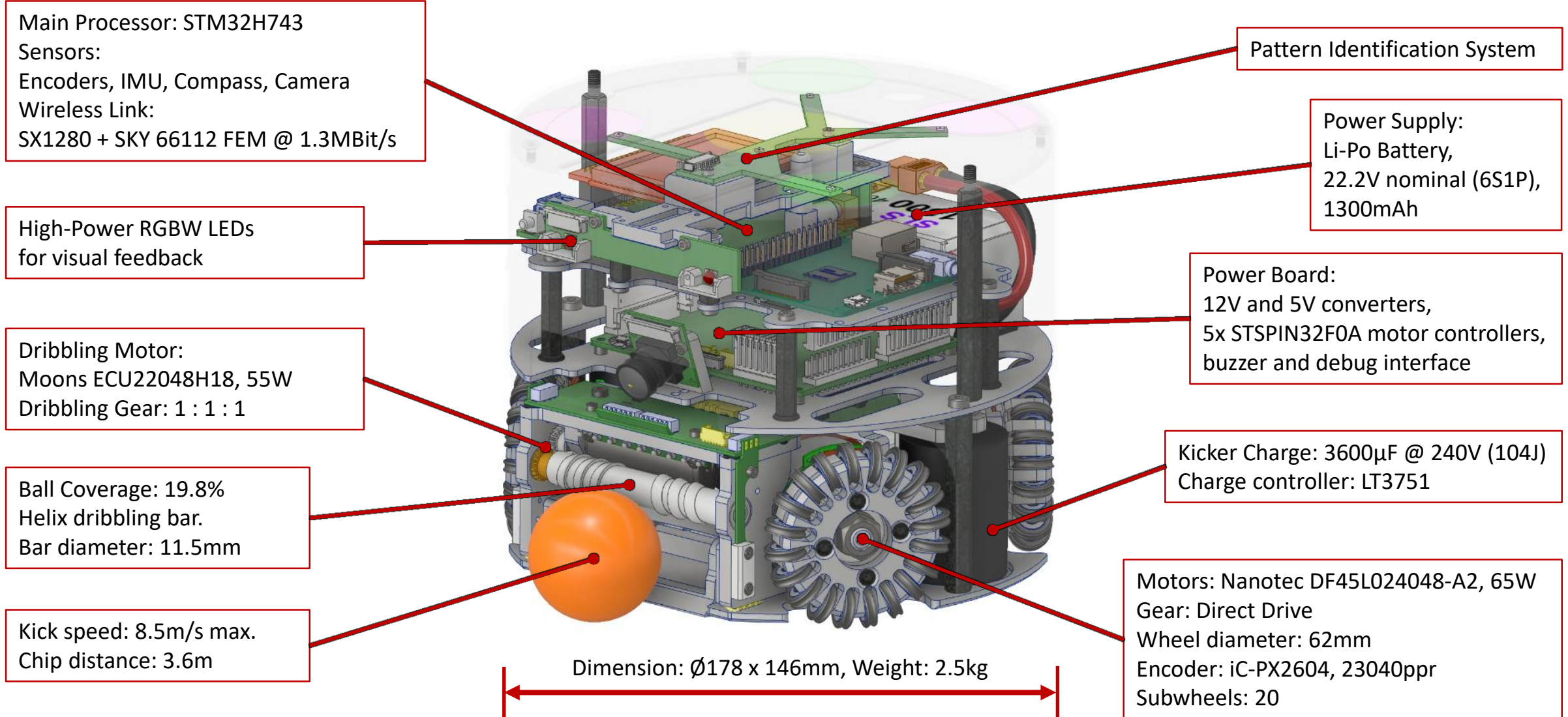

Robot Generation v2020

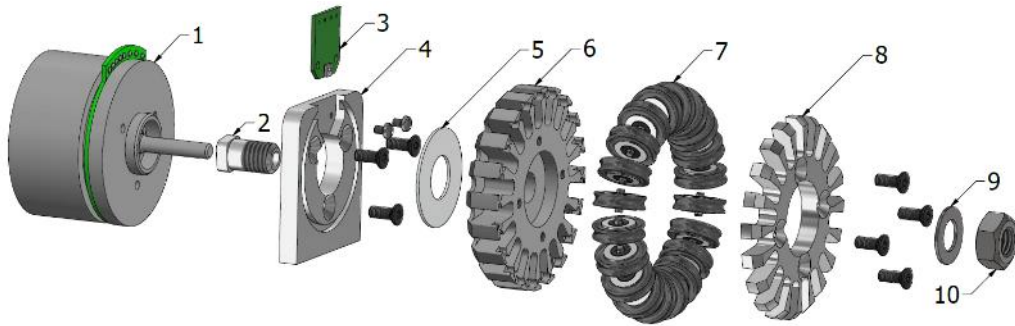

Power Train and Wheels



The usage of 65W motors makes it possible to use a direct drive and still have enough torque for good acceleration. The wheel can be fully removed by removing a single hex nut (10).

The optical encoder disk is embedded into the wheel (5). The detection circuit (3) is fixed to the mounting block (4).

Each subwheel consists of 5 components. A X-Ring (1) provides optimal grip to the carpet. An aluminum body (2) acts as a carrier for all other components.

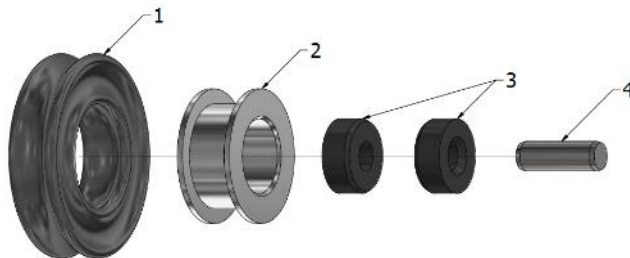

Two friction bearings (3) reduce vibration and wear on the bearing. A simple dowel pin (4) is used as an axis. Apart from the roller body all components are available off the shelf.

Wheel Size Key Factors and their Influence

Top speed: A larger wheel reaches a higher top speed over ground. A small wheel has less top speed at the same angular velocity.

Gear ratio: A reduction gear reduces top speed but increases torque at the same power requirement.

Energy consumption: The battery has a limited amount of energy and should ideally last at least for a game half.

Space constraints: Larger wheels have to be further away from the outer shell to not violate the 180mm diameter rule. This reduces available space inside the robot. The dribbling bar width is also reduced when using large wheels.

Arrangement of Wheels

An even 90° spacing is ideal as it reduces friction effects from subwheels, making control easier.

As this severely limits the dribbling bar width the front angle is usually increased to around 120° while the rear angle stays at 90°.

Design for Durability

It is advisable to design power train and wheels such that they are still operational even with small defects. The wheels are usually exposed and must sustain skirmishes and ball impacts. As an example tolerances should be high enough so that a deformed roller body can still rotate in its pocket.

Kicker

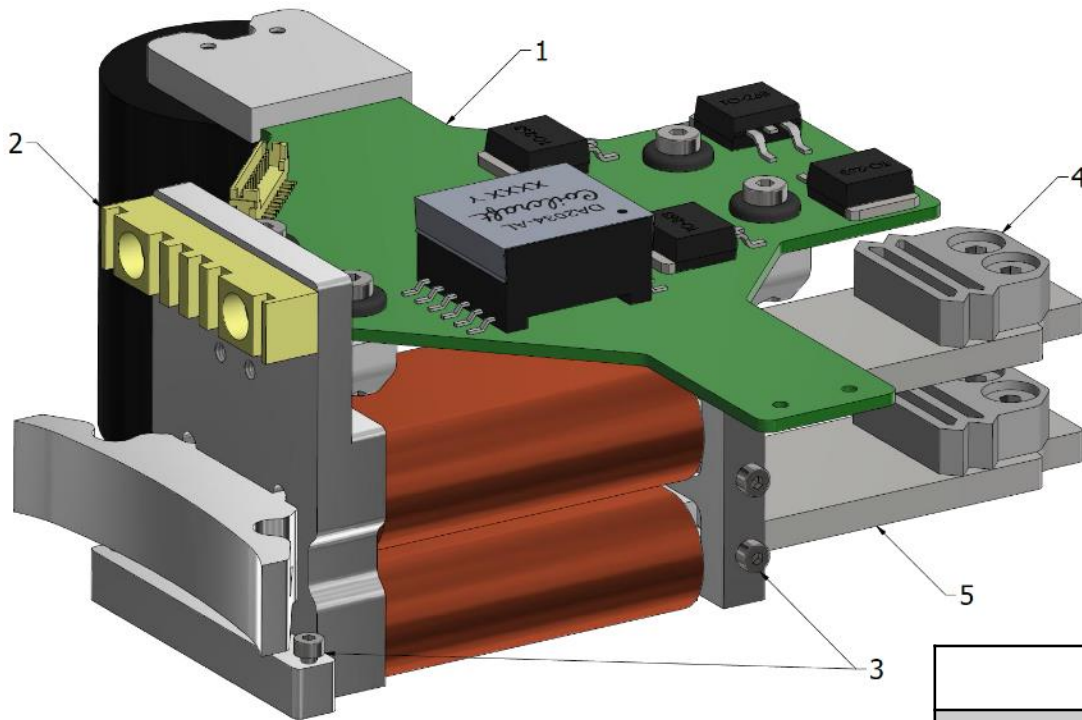

The kicker module consists of two plungers (5) made of aluminum and ferromagnetic steel. Two 3D printed flexible dampers absorb impact energy (4). Retraction springs are mounted on (3). The kicker board uses a line transformer and the LT3751 IC to charge two 1800 μ F capacitors to up to 250V within two seconds.

Key Factors for High Kick Speeds

Coil windings: More turns increase the magnetic field strength but they also increase the resistance of the coil. A thin wire allows for more turns but has less current capability.

Coil resistance: A higher resistance reduces average current through the coil at the same voltage.

Coil current: A high current leads to a strong magnetic field. Care must be taken not to overheat or burn the coil wire. Cutting off the current is challenging for electronic components. Proper freewheeling to dissipate the energy in the coils is important.

Capacitor voltage: A higher voltage leads to a higher current through the coil, thus increasing the magnetic field strength. Voltage also has a squared effect on the stored energy in the capacitors.

Capacity: A higher capacity leads to a longer current pulse through the coils. Recharging takes longer with a higher capacity.

Plunger mass: The mass of the plunger determines its acceleration and final velocity. A higher mass leads to less acceleration.

In a perfectly coordinated kicker the current pulse is as long as the plunger needs time to travel to the spot where it hits the ball. A longer pulse will waste energy, the plunger cannot move any further. A short pulse will not accelerate the plunger long enough to reach a high velocity.

Kicker Specification

Coil Inner Shape	27x6mm
Coil Length	46mm
Wire	Enameled Copper, 0.63mm
Turns	420-500
Layers	6-7
Capacity	3600 μ F
Max. Voltage	250V



Robot Cover and Dribbler

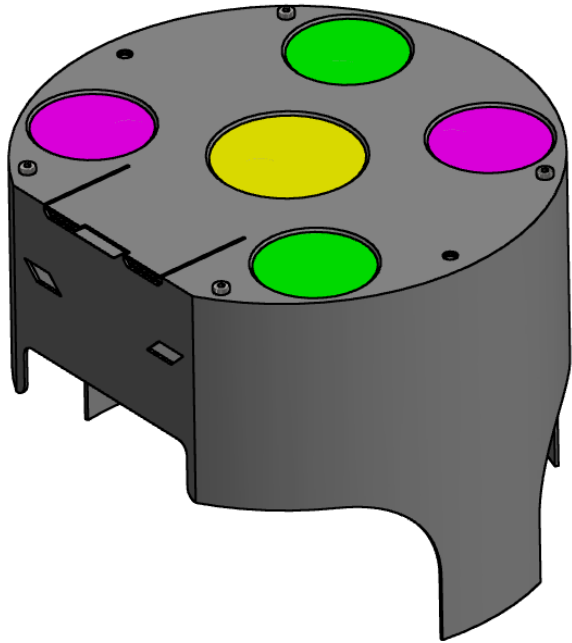

The cover is 3D printed with PETG and has a wall thickness of 1.2mm. It will be fully covered with a adhesive sticker containing logos and robot number. The cover and the sticker form a very robust compound material. While we expect the cover to crack eventually it will still be fully functional due to the sticker holding everything together. As the covers are 3D printed they are easy to replace in case of too many cracks.

The cover has cutouts for the eyes of the robot, containing powerful RGBW LEDs for indication and debug purposes. Furthermore the team color paper can be easily pulled out towards the front and turned around to change the robots team color.

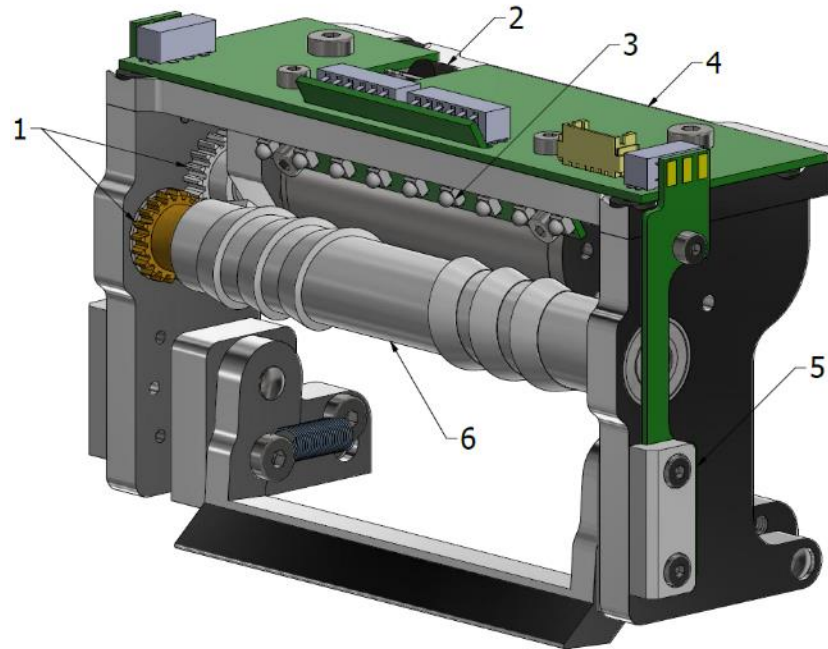

The dribbler module consists of the dribbling device itself and electronics for two different IR circuits. Rotation from the motor is transferred via three gear wheels (1) with all the same number of teeth to the roller with a helix shape to center the ball (6). Left and right is a break beam installed (5) to detect the ball for kicks. Above the roller is an IR array (3) to detect the exact ball position with an update rate of 1kHz. Processing is done on a small PCB (4) which also has a temperature sensor (2) to allow direct measurements of the dribbler motor temperature.

Key Factors for Ball Handling

The dribbler has two primary objectives: Absorbing energy while catching a ball and reducing vibrations while dribbling the ball.

In most cases absorbing impact energy requires a hard damping material, while a good vibration reduction is achieved with a softer material. The damping material is usually placed behind the dribbler module which can tilt backwards.

The material of the dribbling bar can also damp the ball. It is also important that the material is relatively rough, so that it sticks well to the ball to transfer spin.

All these aspects need to be balanced to achieve good catching and good dribbling performance.